



Bilby 3D

MATERIAL DATA SAFETY SHEET

Issued in Australia by Bilby 3D Pty Ltd.

The attached Material Data Safety Sheet has been prepared by the manufacturer outside Australia.

In accordance with Australia WHS regulations the following Australian contact details apply

Section 1: AUSTRALIAN COMPANY DETAILS

In Australia the product is imported and distributed by:
Bilby 3D Pty Ltd

Mailing Address :

Kingsgrove Business Centre, 7/192 Kingsgrove Rd, Kingsgrove NSW 2208

Head Office Address :

Kingsgrove Business Centre, 7/192 Kingsgrove Rd, Kingsgrove NSW 2208

Contact Phone: 1800 847 333

Section 2: AUSTRALIAN EMERGENCY CONTACT

Emergency Contact

In the event of an emergency please contact:

Poisons Information Centre 24 hour Telephone Advice Line on 13 11 26

Section 3: AUSTRALIAN ISSUE DATA

Date of Issue : 1 March 2020

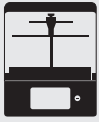

Liquid Crystal OPUS



DATASHEET

Overview

From the inventors of LCD 3D Printing, the Photocentric LC Opus delivers fast, highly accurate prints suitable for a huge variety of industries and applications. With its rugged construction, the LC Opus has been designed to provide reliable and repeatable performance. Equally at home in a dental laboratory or engineering workshop, its intuitive and simple operation makes it perfect for beginners and experienced users alike.

Product Highlights

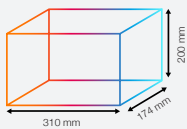

Impressive build volume of 310 x 174 x 220mm (12.2 x 6.9 x 7.9")



XY resolution of 81µm provides scanned data accuracy of ≥95% at <100µm and ≥70% at <50 µm



Incredibly fast cure speed of 2 seconds per layer at 50µm layer thickness



A custom monochrome screen in a unique design supports consistent and reliable high performance



Photocentric's patented peel release technology 'Vat-Lift' ensures reliability over large surface area printing



Robust double-sealed vat construction with practical carry handles and pouring spout

Photocentric

UK Photocentric Ltd. Cambridge House, Oxney Rd, Peterborough, PE1 5YW email: info@photocentric.co.uk
USA Photocentric Inc. 2205 West Parkside Lane, Phoenix, 85027, AZ email: info@photocentricusa.com
www.photocentricgroup.com





Construction

Meticulous attention to detail has been taken with the component selection for the LC Opus. We work with carefully chosen suppliers and where required will specify components to meet our exacting requirements. Every element of the design and manufacture of the LC Opus is undertaken at our UK manufacturing facility.

Highlights

- Even light distribution - we apply an incredibly tight tolerance to the LEDs we use. We select for both intensity and wavelength ensuring a repeatable, uniform cure.
- Ultra-quiet PWM fans provide quiet, efficient cooling for the high-powered LED array enabling LC Opus to run at high temperatures for sustained periods.
- Trinamic motor drivers enable smooth and quiet operation.
- Precision engineered mechanical components support reliable and consistent performance.
- Rugged aluminium construction, solvent resistant paint, and a robust, long-life vat.
- All PCBs are designed by Photocentric and manufactured in the UK.
- Tough annealed red plastic hood is resistant to cracking from chemical exposure.

Operation

A simple 'plug and play' operation complemented with Photocentric's intuitive STUDIO software, means that LC Opus is suitable for both experienced and novice users.

Calibrated in the factory, LC Opus is delivered ready to print straight out of the box. With simplified homing and an innovative new vat design which includes a self-cleaning mode, LC Opus is your trusted production partner.

Highlights

- Interchangeable platforms without the need to re-calibrate.
- Highest quality purpose built screen.
- Large capacitive 7" touch screen.
- Robust double-sealed vat construction with practical carry handles and pouring spout.
- Intuitive STUDIO software supported with regular performance and service upgrades.
- Photocentric's patented peel release technology - 'Vat-Lift'.



Product Dimensions

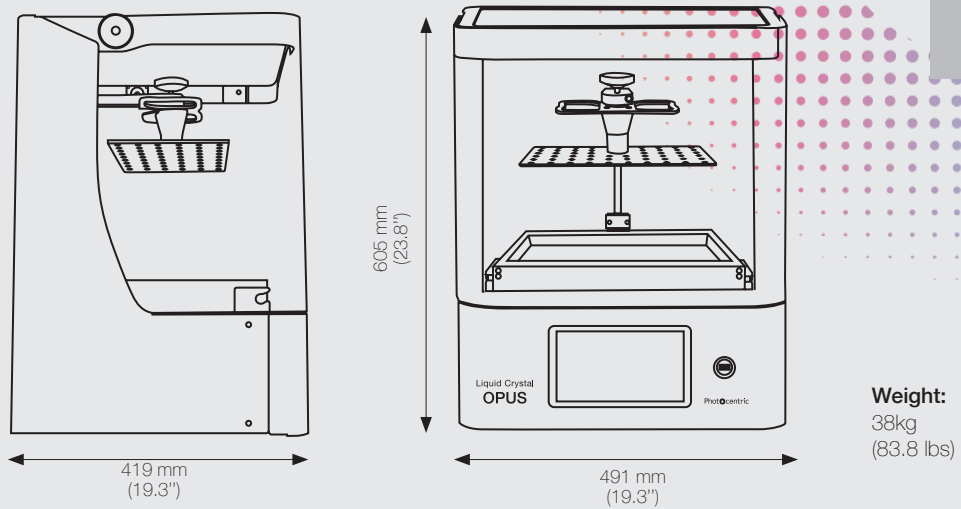

Weight:
38kg
(83.8 lbs)

Full Technical Specifications

Performance	User Interface and Operation	Software
<ul style="list-style-type: none"> Build volume: 310 x 174 x 220mm (12.2 x 6.9 x 7.9"). Print layer thickness: 25, 50 and 100µm. Layer thickness of >100µm is dependent upon resin properties. 14" monochrome 4k LCD screen. Print Speed: 18mm per hour. Cure Speed: 2 seconds per layer at 50µm. Light Output intensity - LCD screen: 5mW/cm² Resolution: XY resolution of 81µm provides scanned data accuracy of ≥95% at <100µm and ≥70% at <50 µm Photocentric's patented peel release technology - 'Vat-Lift' Light output wavelength: 410nm 	<ul style="list-style-type: none"> Calibrated in the factory enabling quick set-up and installation on site. Large capacitive touch 7-inch screen. Integrated Photocentric control system for optimum performance and in-field updates. New vat with self-cleaning software option. Easy clean platform and chassis featuring robust double-sealed vat construction with practical carry handles. Screen cartridge with a tight tolerance facilitating easy replacement and easy servicing. Interchangeable platform options without recalibration - easier to handle, wash, homing simplified. 	<p>Intuitive Photocentric STUDIO (software licence)</p> <p>Minimum System Requirements</p> <ul style="list-style-type: none"> Operating System Windows 7, 8 or 10 Minimum 2.0 GHz processor speed 2 cores – recommended 4 cores GPU capable of OpenGL version 3.0 or higher NET framework version 4.0 64bit system: recommended 4GB 32bit system: recommended 2GB
		Connectivity
		<ul style="list-style-type: none"> Wi-Fi Ethernet USB 3.0 for fast file transfer

Construction		
<ul style="list-style-type: none"> Rugged aluminium construction with solvent resistant paint. 4k Monochrome 14" screen(3840 x 2160px with a pixel density of 314.7 PPI) Very flat, high tolerance glass. Platform print arm constructed from single billet of aerospace grade aluminium. 	<ul style="list-style-type: none"> Tough annealed red plastic hood is resistant to cracking from chemical exposure. Precision engineered components including THK linear rails from Japan. Tinamic motor drivers deliver extremely quiet and robust performance. 	<ul style="list-style-type: none"> Ultra-quiet PWM fans provide efficient cooling for high powered LEDs. Vibration damping rubber feet on base. Weight: 38kg (83.8 lbs)